



WWW.ROCKANDSTORMPLAST.COM

Product Catalog

NEW PRODUCT YEAR 2024



Why Rock And Storm Plast?

RockandStormPlast manufactures durable, high-quality bottles. They specialize in eco-friendly, customizable designs for various industries. Reliable and innovative.

- Customizable bottle designs.
- High durability and reliability.
- Innovative manufacturing processes.
- Industry-leading customer satisfaction.



The PETformance you can trust, for a future that's crystal clear.

FROM THE DESK OF OUR DIRECTOR

Welcome to Rockandstormplast, established in 2012, where innovation meets excellence in the manufacturing of PET preforms, PET bottles, and LD sheets. Serving distilleries and bottling plants across Punjab, Haryana, Himachal, and Delhi NCR, we are dedicated to setting benchmarks in the industry.

As Chairman, I am honored to lead a team that shares a vision of innovation, sustainability, and quality.

Our PET bottles cater to the diverse needs of liquor, juice, water, and soda industries, embodying durability and reliability.

Driven by a relentless pursuit of excellence, we prioritize sustainability in everything we do. Our manufacturing processes are designed to minimize environmental impact without compromising on product performance. This dedication allows us to empower outdoor enthusiasts globally, providing them with gear they can trust in any conditions.

180ML BOTTLES

AA 180 mL container is compact and versatile, commonly used for packaging small quantities of liquids such as beverages, sauces, or cosmetics. Its rounded shape ensures efficient storage and easy handling, making it ideal for retail products that require convenient packaging and display.

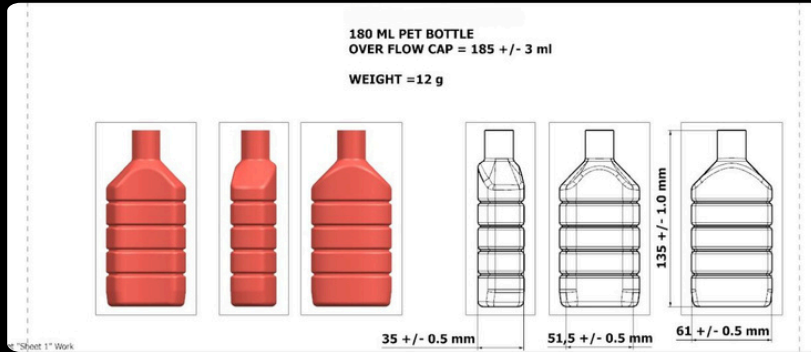

180-ML_PET BOTTEL



180ML OVAL

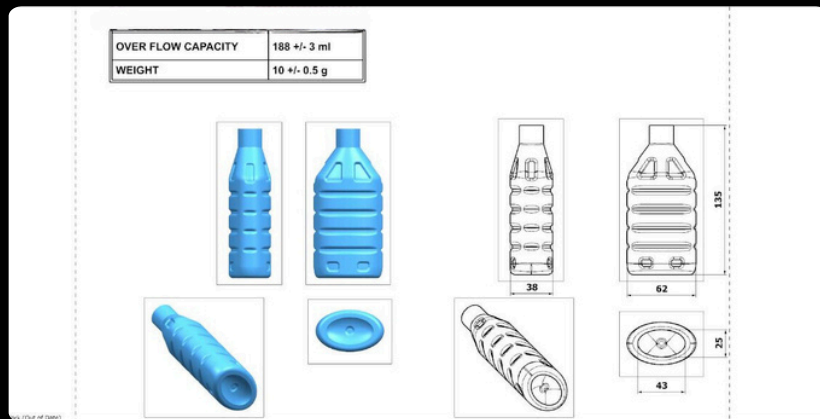

180ML OVALI

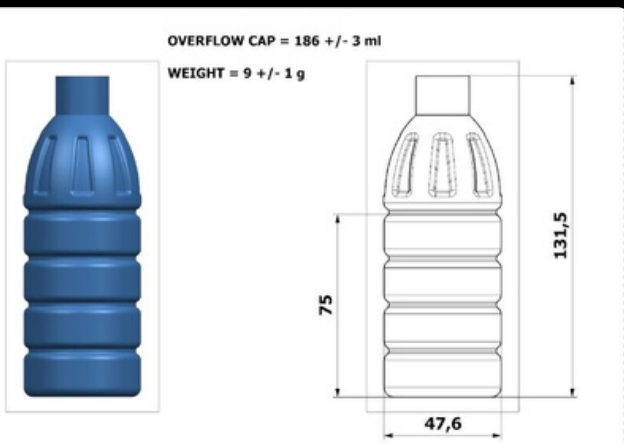

180ML ROUND

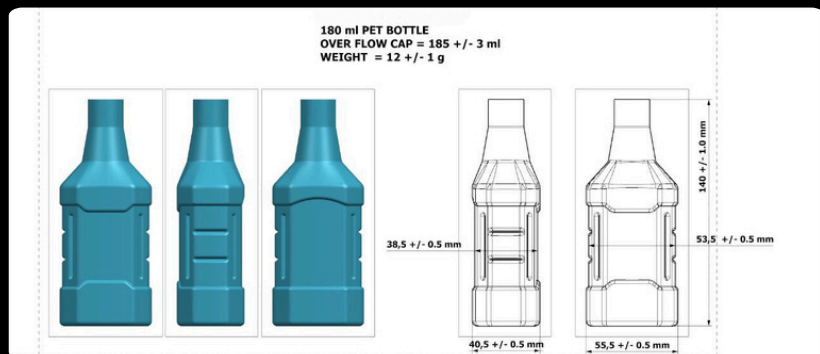

180ML SQUARE

200ML BOTTLES

A 200 mL round container is a versatile choice for packaging liquids such as beverages, oils, or sauces. Its shape promotes efficient storage and handling, making it popular in both retail and industrial settings. This size is ideal for single-serving portions or small quantities of various products.

200 ml
ROUND

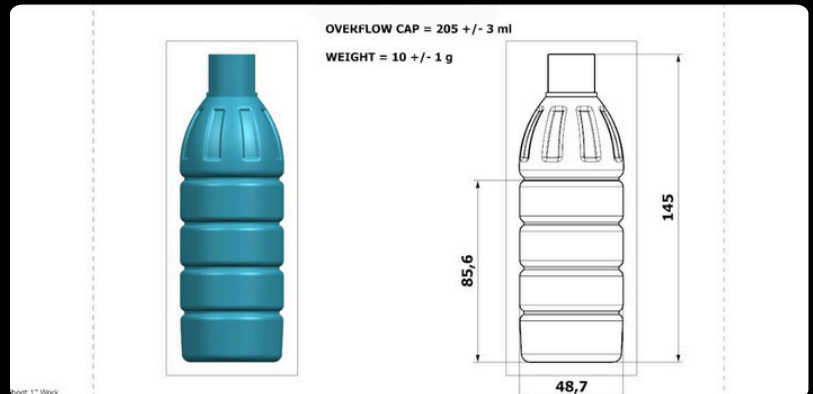

200ML ROUND

200 ml
FLAT



200ML FLAT

200ML
CHAPTA

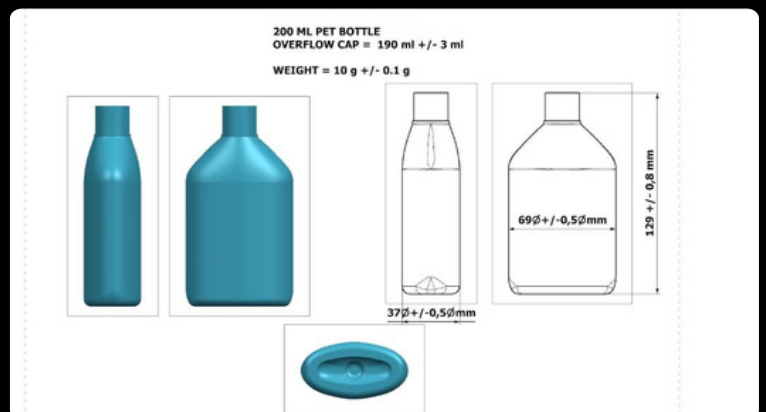

200ML CHAPTA

375ML BOTTLES

375 mL bottle range is a compact and versatile container commonly used for packaging beverages such as wine, spirits, or oils. Its shape facilitates easy handling and storage, making it ideal for retail shelves and transport. The size is popular for single servings or smaller quantities, appealing to various consumer preferences.

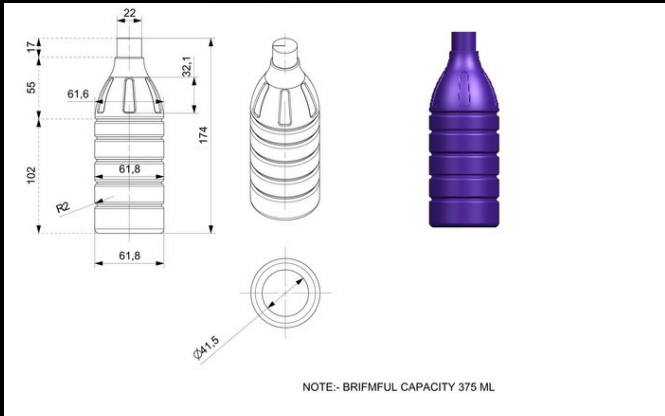

375ML ROUND 1

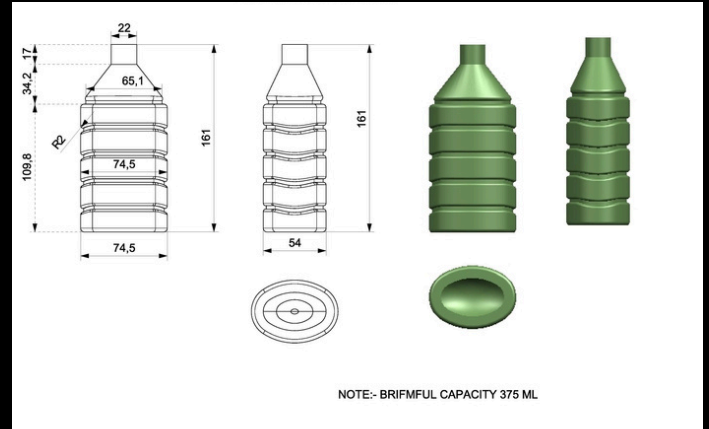

375ML OVAL



375ML SQUARE



375ML ROUND

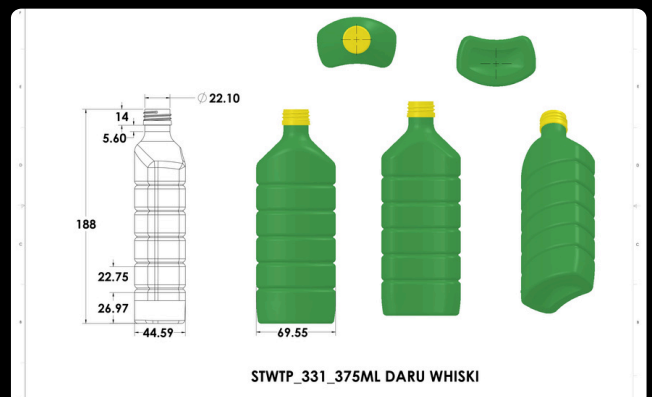

375ML KIDNEY

750ML BOTTLES

The 750-ML Long bottle is elegantly designed, perfect for showcasing premium beverages. Its elongated shape offers a sleek and sophisticated appearance, ideal for wine, spirits, or specialty drinks. The clear glass highlights the contents, while its sturdy construction ensures durability and ease of handling.

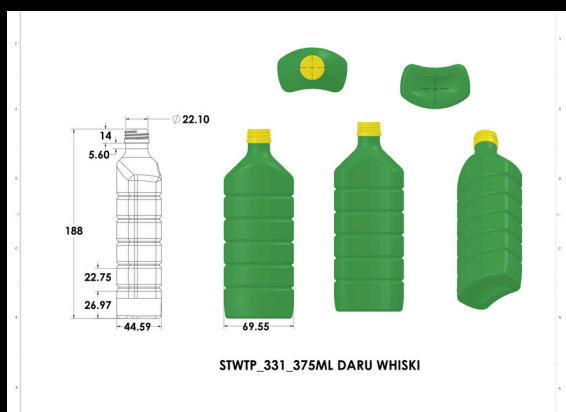

750ML ROUND

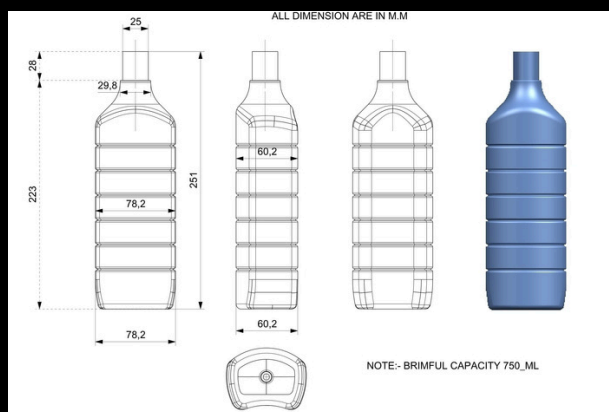

750ML KIDNEY

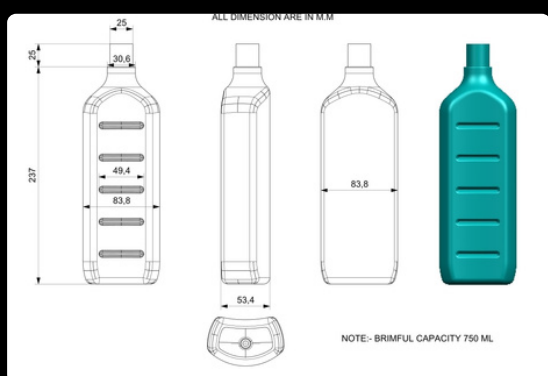

750ML CASH

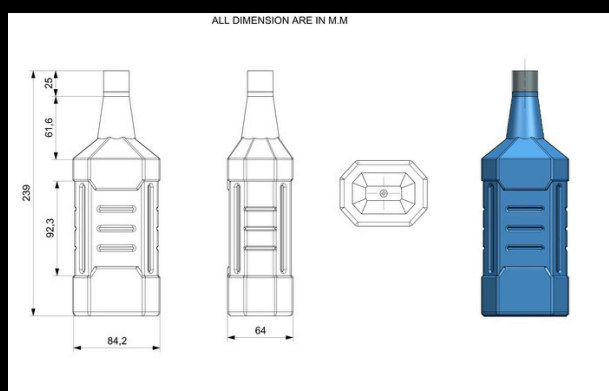

750ML SQUARE

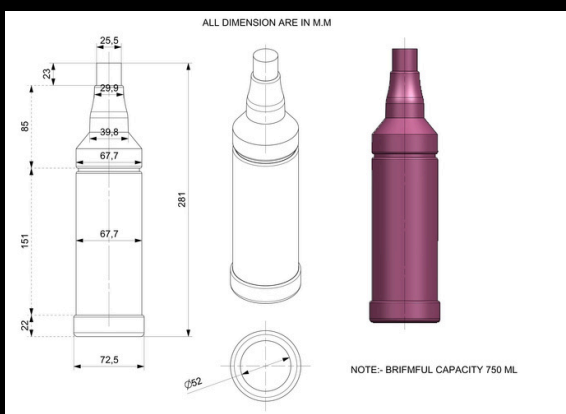

750ML LONG ROUND

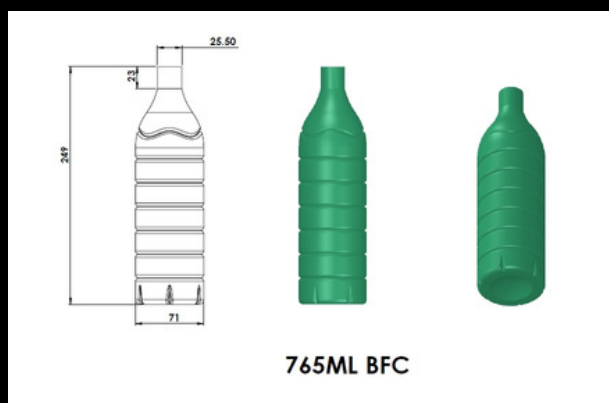

765ML BFC

750ML ROUND BFC

MACHINERY

We offer industrial machinery for diverse needs. Our selection includes LD/HD blow film extension machines for plastic production, agglomerators (SSAG-20KG) for material processing, and 800ml bottle sealing bag making equipment.



LD/HD BLOW FILM
EXTENSION MACHINES

LD/HD BLOW FILM EXTENSION
MACHINE SS LD-HD
450/750AA



AGGLOMERATOR WITH
STARTER SSAG-20KG



PET BOTTLE PREFORMS

We offer a variety of PET bottle preforms in different sizes and neck finishes to suit your needs. Preform sizes range from 9.2 gm to 39 gm, with neck diameters of 25 mm and 28 mm. We also provide preforms with a T.S.T neck finish. For your reference, here are some mold numbers associated with specific preform sizes: k866 (39 gm, 29/35 mm neck), k755 (25 gm, 28 mm neck), and k170 (14 gm, 25 mm neck)



39 gm - (29/35 MM Neck)

25 gm - (28MM without caller Neck)

23 gm - (28Mm Neck)

15 gm - Long PCO 28 MM Neck

14 gm - (25Mm neck)

12 gm - (25Mm neck)

10 gm (25Mm neck)

9 gm - (T.S.T neck)

9.2 gm - (25Mm neck)



WWW.ROCKANDSTORMPLAST.COM

Contact

SANDEEP BANSAL (MONU)

CHAIRMAN SDIC
CHAIRMAN GOVT. ITI (INDUSTRIAL TRAINING
INSTITUTE)
PRESIDENT ROTARY CLUB SANGRUR "DYNAMIC"

- Udhwal Road, Vill. Badrukhan
SANGRUR (PB) 148001
- Rockandstormplast@gmail.com
- +91 9216550329
+91 9876849329

RISHAV BANSAL

- +91 76969 83148
- RishavBansal.7696@gmail.com



The PETformance you can trust, for a future that's crystal clear.

WWW.ROCKANDSTORMPLAST.COM